

Using Small Cells for Enhancing 5G Network Facilities

Ioannis P. Chochliouros^{1,2}, Alexandros Kostopoulos^{1,2},
Ioannis Giannoulakis³, Anastasia S. Spiliopoulou¹,
Maria Belesioti^{1,2}, Evangelos Sfakianakis^{1,2}
¹Hellenic Telecommunications Organization S.A. (OTE)
²Research Programs Section, Maroussi-Athens, Greece
^{1,2}{*ichochliouros, mbelesioti, alexkosto, esfak*}@oteresea.gr
¹*aspiliopoul@ote.gr*

Anastasios Kourtis³, Emmanouil Kafetzakis⁴
³National Center for Scientific Research “Demokritos”,
Greece {*giannoul, kourtis*}@iit.demokritos.gr
⁴ORION Innovations Private Company, Greece
mkafetz@orioninnovations.gr

Abstract—The 5G ESSENCE project context is based on the concept of Edge cloud computing and Small Cell-as-a-Service (SCaaS) and further “promotes” their role and/or influences within the related 5G vertical markets. 5G ESSENCE’s core innovation is focused upon the development/provision of a highly flexible and scalable platform, offering benefits to the involved market actors. The present work identifies a variety of challenges to be fulfilled by the 5G ESSENCE in the scope of an enhanced architectural framework. The proposed technical approach exploits the profits of the centralisation of Small Cell functions as scale grows through an edge cloud environment based on a two-tier architecture with the first distributed tier being for offering low latency services and the second centralised tier being for the provision of high processing power for computing-intensive network applications. This permits decoupling the control and user planes of the Radio Access Network (RAN) and achieving the advantages of Cloud-RAN without the enormous fronthaul latency restrictions. The use of end-to-end network slicing mechanisms allows for sharing the related infrastructure among multiple operators/vertical industries and customizing its capabilities on a per-tenant basis, creating a neutral host market and reducing operational costs.

Keywords—5G; Cloud-enabled Small Cell (CESC); Mobile Edge Computing (MEC); Network Functions Virtualization (NFV); Radio Resource Management (RRM).

I. INTRODUCTION

Up to now several visions of 5G have been proposed and their basic features, apparently, converge to the idea that “any person or item can connect at arbitrarily high data rates, from any place, and with extremely low latency” [1], [2]. How these traits can be realised depends on several factors, including combinations of existing types of communication networks, as well as new and ground-breaking implementations. 5G solutions envisage consolidation of cellular, Internet of Things (IoT), and Wi-Fi networks; this list may be enriched with broadcast networks and automotive systems. Furthermore, in order to achieve higher transmission rates, new wireless solutions, such as exploitation of millimeter-Wave (mmWave) bands, are expected to be utilised [3]. The reasons behind these developments are well grounded in practical requirements. Separate radio interfaces are required for the different

solutions, such as cellular over IoT and additionally, the exigency for extremely low latency drives inexorably to ultra-dense deployments and usage of higher frequencies [4].

The main problem of the proposed 5G solutions is that they neither have been adequately tied to a solid business case, nor well integrated to the legacy infrastructure of network operators and the rest of actors within the communications ecosystem. This is not surprising, considering the lack of new monetisable revenue streams [5]. For years, operators have been making efforts to launch new services, such as image messaging, video calls, location based services and so on (and even some examples of Over-The-Top (OTT) players like Skype have achieved to deliver added value solutions); however, the average revenue per user remains low. Therefore, 5G needs not only to target to new technological solutions, it should also take into account current economic position of telecom operators and also to pave the way for producing new benefits that will create new markets and services, so that additional 5G actors such as multimedia content providers and vendors are also able to increase their profits.

If there are no new revenues, there arises the ultimate necessity that 5G reduces operators’ costs. To address this requirement, 5G ESSENCE introduces innovations in the fields of network softwarisation, virtualisation, and cognitive network management. It also provides a highly flexible and scalable platform, capable of supporting new business models and revenue streams by creating a “neutral host market” and ultimately reducing operational costs by providing new opportunities for ownership, deployment, operation and amortisation.

Entering the second phase of 5G-PPP program activities suggests that communication networks become sufficiently flexible to handle a range of applications and services originating from different domains/verticals. At the same time, a transformation towards a significant reduction in cost and the optimal allocation of available resources take the place of initial Key Performance Indicators (KPIs) for driving capacity growth, and coping with the numerous barriers on the infrastructure and management domains. On the users’ side, a high level of personalised services, along with edge mobile capabilities and innovative services are anticipated, since

customers require added value to their choices in order to accommodate specialised requirements with greater quality of both perception and experience. The 5G ESSENCE approach allows new stakeholders to dynamically enter the network value chain by building upon and leveraging the outcomes of 5G-Public Private Partnership (PPP) Phase-1 SESAME project [6], as well as several other Phase-1 research activities. Small Cell operators, network operators, and OTT players, are offered access on-demand to “evolved” Small Cell platforms, enhanced with mobile edge computing capabilities. Moreover, 5G ESSENCE will provide advanced network virtualisation, distributed service management, and the full potential of a network embedded cloud, by building upon network slicing and isolation, and then providing this capability to multiple operators (tenants).

II. THE “5G ESSENCE” CONCEPTUAL APPROACH

A. Market Positioning and Vision

During 5G-PPP Phase-1, the ongoing SESAME project evolves the small cell concept by integrating processing power (i.e., a low-cost micro server) and by enabling the execution of applications and network services, in accordance to the Mobile Edge Computing (MEC) paradigm [7]. It also provides network intelligence and applications by leveraging the Network Function Virtualisation (NFV) concept [8]. The SESAME platform consists of one or more clusters of ‘Cloud - Enabled’ Small Cells (CESCs) [9], which are devices that include both the processing power platform and the small cell unit. CESCs can be deployed at low and medium scale venues and support multiple network operators (i.e.: multitenancy) and further, network services and applications at the edge of the network.

In this context, SESAME has developed several small cell related functions as Virtualised Network Functions (VNFs) [10], such as the GPRS Tunnelling Protocol (GTP) en-/decapsulation of data packets. Also, SESAME has demonstrated so far that some network related functions (such as content caching, firewalls and monitoring) perform adequately well when running as VNFs in the developed micro-server infrastructure (coined as “Light Data Centre” - Light DC) [11].

The 5G ESSENCE proposal leverages results from the SESAME project, as well as from other 5G-PPP Phase-1 projects (COHERENT, SPEED 5G, and SONATA mainly), in order to provide an evolution of the SESAME platform and to meet the 5G-PPP Phase-2 requirements (i.e., to cover the specific network needs of the vertical sectors and their interdependencies). It enhances the processing capabilities for data that have immediate value beyond locality, it addresses the processing-intensive small cell management functions, such as Radio Resource Management (RRM)/ Self Organising Network (SON) and, *finally*, it culminates with real life demonstrations. For all the above, 5G ESSENCE suggests clear breakthroughs in the research fields of wireless access, network virtualisation, and end-to-end (E2E) service delivery. The existing virtualised resources of small cells will be exploited to their full potential and in a dynamic way, supporting extremely low-latency and the delivery of high-performance services, greater network resiliency, and substantial capacity gains at the

access network for the next 5G stage. To achieve these goals, 5G ESSENCE will build on the SESAME project by developing a distributed edge cloud environment (coined as “Edge Data Centre” -Edge DC-), based on a two-tier architecture: the first tier, i.e., Light DC, will remain distributed inside the CESCs for providing latency-sensitive services to users directly from the network’s edge. The second tier will be a more centralised, ‘high-scale’ cloud, namely the Main Data Centre (Main DC), which will provide high processing power for computing intensive network applications. It will also have a more centralised view so as to host efficient Quality of Service (QoS) enabled scheduling algorithms. Both these cloud tiers will form the Edge DC in 5G ESSENCE terminology, which will be viewed as an integrated cloud infrastructure from the upper management and orchestration layers.

With respect to the radio resources of the wireless access network, it is well known, (and from the results of SESAME project it became even clearer), that the capacity offered from small cells does not scale beyond a specific threshold due to interference. Existing radio resource allocations remain inadequate due to the lack of a centralised coordination, especially in urban areas and environments with high density of users. As a remedy, the Cloud-Radio Access Network (C-RAN) approach ([12]-[14]) has introduced centralised BaseBand Units (BBUs) for processing both the control and user planes, in order to support flexible scaling and sophisticated interference coordination techniques. However, the significant capacity gains proposed by C-RAN come with a high cost for the fronthaul network since the fronthaul requirements for C-RAN are in the order of 6 Gbps bandwidth for small cell sites and of latency less than 0.5ms Round Trip Time (RTT) [15]. In other words, direct fibre lines (i.e., without switching or buffering) or mmWave links are necessary for the small cell fronthaul connections. In the case of macro-base stations, the fronthauling cost can be affordable, but in the small cell case, it is too expensive and not realistic. Small cells can be connected to fronthaul through a variety of technologies (cable, public fibre, and microwave) and there are scenarios in which they are deployed without a central planning. Even if public leased fibre or multi-gigabit Ethernet were available everywhere, that would not be sufficient (mainly because of the latency requirements).

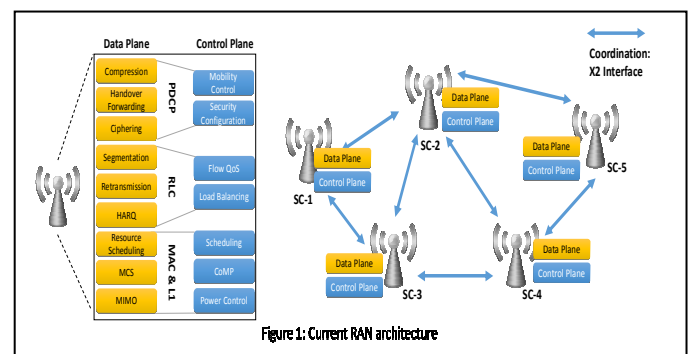

Fig. 1. Current RAN architecture

Correspondingly, the SESAME project applies some advantageous distributed RRM/SON techniques for managing

interference and increasing capacity. The coarse coordination achieved through X2 interface targets to reduce interference but it is less efficient for allocating resources in a unified fashion among multiple cells in comparison with the C-RAN approach (see, e.g., Fig. 1).

B. Challenges for Growth

5G ESSENCE proposes a pioneering approach to alleviate the consequences of extreme network densification and of the insufficient management of the scarce network resources, as illustrated in Fig. 2.

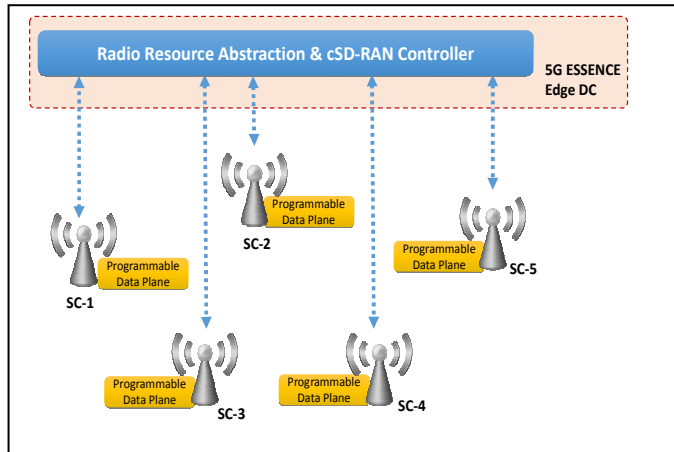

Fig. 2. 5G ESSENCE approach to radio resource abstraction

It suggests decoupling the control and user planes for the Radio Access Network (RAN), similarly to Software Defined Networking (SDN) in data networks [16] and claiming the benefits of C-RAN without the enormous latency restrictions in the fronthaul [17]. Thus, the project envisages that the Small Cell network functions related to the user/data plane will remain distributed [18], while the control plane functions will be disaggregated from the RAN and hosted at the Main DC, using Commercial-of-the-Self (COTS) hardware. Although the design of such a centralised Software Defined-RAN (cSD-RAN) controller is a challenging task, since also real time feedback of radio conditions should be taken into account, the distributed and network-integrated cloud inherited by SESAME so far is adequate for hosting controllers based on spatial segmentation, so this aspect can accelerate research results achieved to date. In particular, centralization brings immediate benefits for operators seeking to improve network efficiency and quality as well as coming to grips with digital convergence transformation [19]. Further, 5G ESSENCE aspires to include multiple Radio Access Technologies (RAT) in its network architecture [20], representing an important step towards fulfilling the vision of 5G wireless networks, where intelligent deployments aim to achieve higher performance and flexibility and to offer more efficient spectrum utilisation.

Clear breakthroughs are foreseen also in the fields of high-performance virtualisation, service delivery and resource orchestration, targeting the critical issues of resource efficiency and latency reduction. These will be achieved through the support of a converged cloud-radio environment, the orchestration of diverse types of lightweight virtual resources,

and the support of live VNF migration. The approach of network control centralisation [21] will not remain only in the radio resource abstraction part, since given the needs for fast resource provisioning and mapping, and for increased abstraction in the management of services, 5G ESSENCE will provide even tighter mapping and closer interactions between the resource orchestration (i.e., deployment, placement, and scaling of VNFs) and service orchestration (i.e., building, coordinating and exposing services to upper layers).

On the domain of hardware technologies, the processing power attached to small cells brings new capabilities to the network as well as new challenges and in the perspective of 5G ESSENCE, the placement of low power/low cost processors to small cells, even with hardware acceleration, will be revised. Although the Cloud-Enabled Small Cell (CESC) platform in SESAME is based on non-x86 architectures (ARMv8), the potential use of x86-based, low-cost and low-power processors will also be leveraged due to their efficiency (small form factor, low powered, passively cooled, low price) and their important share in the market.

The mentioned research domains cover only the technical aspects of the proposed 5G ESSENCE activities. However, a significant part of the project is also devoted to the actual demonstration of the outcomes in vertical industries, as they have been identified by 5G-PPP [22].

In order to showcase that 5G will be able to create a whole new ecosystem for technical and business innovation, 5G ESSENCE unifies computing and storage resources into a programmable and unified small cell infrastructure that can be provided as-a-Service to all related stakeholders [23]. To that end, it provides a clear plan for real life demonstrations in the fields of: (a) multimedia-entertainment; (b) mission critical communications at emergency events, and; (c) in-flight connectivity and entertainment.

In addition to actual demonstrations, 5G ESSENCE is expected to accommodate a much wider range of use cases, especially in terms of ameliorated latency, resilience, coverage, and bandwidth. One of its major innovations is that it provides E2E network and cloud infrastructure slices over the same physical infrastructure, in order to fulfil vertical-specific requirements as well as mobile broadband services in parallel. 5G ESSENCE opens the door to venue owners, e.g., municipalities, stadiums, site owners, and virtually anyone who manages a property and can install and run a local Small Cell network, to deploy a low cost infrastructure and to act as neutral host network and service provider.

Although probably none of such entities would offer static network coverage, many of them could foresee adequate chances for profits generated by exploiting the 5G ESSENCE concepts of multitenant small cells, able to provide wireless network coverage coupled with added value services in close proximity to customers and visitors that belong to multiple network operators and vertical industries.

III. PROPOSED ARCHITECTURAL FRAMEWORK

A. Architectural Framework

The architecture provided so far by the SESAME project (see Fig. 3) acts as a solid reference point for 5G ESSENCE ([24]-[30]). It combines the current 3GPP framework for network management in RAN sharing scenarios and the ETSI NFV framework for managing virtualised network functions [8]. The CESC offers virtualised computing, storage and radio resources and the CESC cluster is considered as a cloud from the upper layers ([27], [28]).

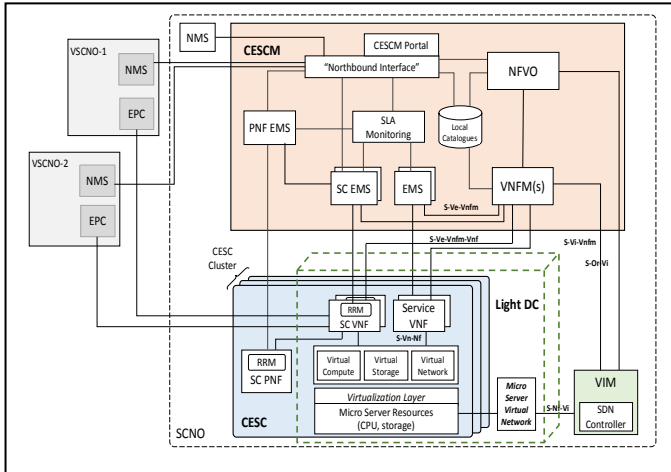

Fig. 3. Overall architecture of the 5G-PPP (Phase-1) SESAME project

This cloud can also be “sliced” to enable multi-tenancy. The execution platform is used to support VNFs [29] that implement the different features of the Small Cells as well as to support for the mobile edge applications of the end-users. Evolving the high level architecture of Fig.3, the technical approach of 5G ESSENCE is presented in Fig.4, where the working architecture with emphasis on the functional elements and interfaces is illustrated. The examination that follows, describes the work split in the proof-of-concept design and implementation. The 5G ESSENCE architecture will allow multiple network operators (tenants) to provide services to their users through a set of CESCes deployed, owned and managed by a third party (i.e., the CESC provider). In this way, operators can extend the capacity of their own 5G RAN in areas where the deployment of their own infrastructure could be expensive and/or inefficient, as it would be the case of e.g., highly dense areas where massive numbers of Small Cells would be needed to provide the expected services. In addition to capacity extension, the 5G ESSENCE platform is equipped with a two-tier virtualised execution environment, materialized in the form of the Edge DC that allows also the provision of MEC capabilities to the mobile operators for enhancing the user experience and the agility in the service delivery. The first tier, i.e., the Light DC hosted inside the CESCes, is used to support the execution of VNFs for carrying out the virtualisation of the Small Cell access.

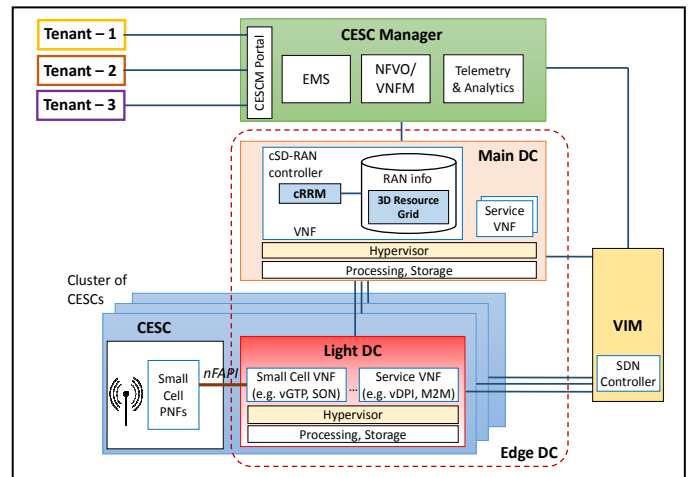

Fig. 4. The 5G ESSENCE architectural composition

In this regard, network functions supporting traffic interception, GTP encapsulation/ decapsulation and some distributed RRM/SON functionalities are expected to be executed therein. VNFs that require low processing power, e.g., a Deep Packet Inspection (DPI), a Machine-to-Machine (M2M) Gateway, and so on, could also be hosted here. The connection between the Small Cell Physical Network Functions (PNFs) and the Small Cell VNFs can be realised through, e.g., the network Functional Application Platform Interface (nFAPI). Finally, backhaul and fronthaul transmission resources will be part of the CESC, allowing for the required connectivity. The second cloud tier, i.e., the Main DC, will be hosting more computation intensive tasks and processes that need to be centralised in order to have a global view of the underlying infrastructure. This encompasses the vSD-RAN controller which will be delivered as a VNF running in the Main DC and makes control plane decisions for all the radio elements in the geographical area of the CESC cluster, including the centralised Radio Resource Management (cRRM) over the entire CESC cluster. Other potential VNFs that could be hosted by the Main DC include security applications, traffic engineering, mobility management, and in general, any additional network E2E services that can be deployed and managed on the 5G ESSENCE virtual networks, effectively and on demand.

B. High Level Architecture aligned to Proposed Scenarios of Use

At the network’s edge, each CESC is able to host one or more service VNFs, directly applying to the users of a specific operator. Similarly, VNFs can be instantiated inside the Main DC and be parts of a Service Function Chaining (SFC) procedure. The Light DC can be used to “implement: different functional splits of the Small Cells as well as to support the mobile edge applications of the end-users. At the same time, 5G ESSENCE proposes the development of small cell management functions as VNFs, which run in the Main DC and coordinate a fixed “pool” of shared radio resources, instead of considering that each small cell station has its own set of resources.

The CESC Manager (CESCM) is responsible for coordinating and supervising the use, the performance, and the delivery of both radio resources and services. It controls the interactions between the infrastructure (CESCs, Edge DC) and the network operators. Also, it handles Service Level Agreements (SLAs), while on an architectural basis, CESCM encompasses telemetry and analytics as fundamental tools for efficiently managing the overall network. The Virtualised Infrastructure Manager (VIM) (see Fig. 5) is responsible for controlling the NFV Infrastructure (NFVI), which includes the computing, storage and network resources of the Edge DC.

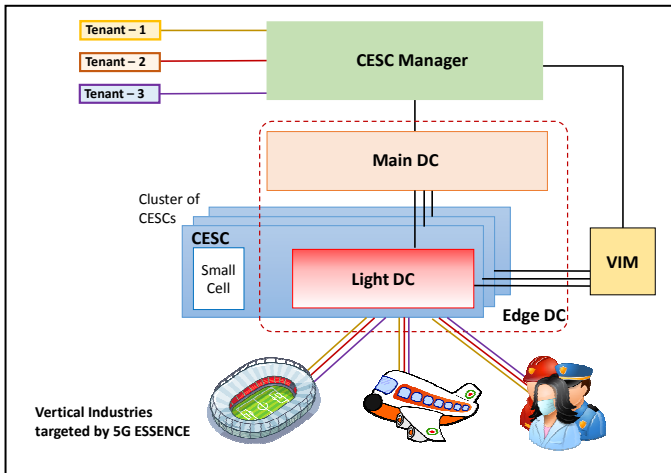

Fig. 5. The 5G ESSENCE high level architecture

It should be mentioned that 5G ESSENCE does not only propose the development and adaptation of the multitenant CESC platform, the virtualisation infrastructure and the centralisation of the software-defined radio resource management described above; it also “addresses” several aspects that affect performance in 5G virtualised environments such as virtual switching [31], VNF migration [32], and Machine Learning algorithms [33], which allow orchestrating diverse types of lightweight virtual resources.

Last but not least, it is worth noting that the abovementioned two-tier architecture of 5G ESSENCE is well aligned with the current views on 5G architecture described by 5G-PPP in [34], where the infrastructure programmability and the split of control and user planes are identified as two key logical architecture design paradigms for 5G [35]. First, 5G ESSENCE achieves infrastructure programmability by leveraging the virtualised computation resources available at the Edge DC. These resources will be used for hosting VNFs tailored according to the needs of each tenant, on a per-slice basis [36]. Network slicing enables network operators and service providers to realise, operate and manage different logical networks (slices) on top of the same physical infrastructure, while providing a diverse set of network/service level differentiation [37]. Second, the Main DC allows centralizing and softwarising control plane small cell functions to enable more efficient utilisation of radio resources coordinated among multiple CESCs [38]. In addition to the abovementioned aspects, 5G ESSENCE contributes to other 5G architectural concepts identified in [34], such as e.g., the

realisation of the network slicing concept [39], which is a fundamental requirement of 5G ESSENCE for enabling that multiple tenants and vertical industries share the same CESC infrastructure.

Actors in the European telecom scene are at a major turning point: mobile network traffic is rising and subscribers’ revenue is declining [40]. In this context, 5G ESSENCE will explore the means to deliver its achievements to the market, with emphasis in the quantification of benefits, especially in terms of total cost of ownership, revenues and profits. It will allow the sharing of existing and new infrastructure by many operators in a multitenant environment, thus enabling new business models that will help new entrant market players to develop and analyse the perspectives of potential win-win strategies based on the developed solutions ([41], [42]). Key actors, revenue streams, and cost/performance drivers of the various RAN partitioning options will be identified. The main benefits of 5G ESSENCE include the maximisation of resource usage, the reduction of equipment and management costs, and QoS improvement, thus encouraging network innovation and the deployment of distinct network services ([43], [44]). These features can be applied directly into the 5G ESSENCE architecture and result in many general key benefits, such as CAPEX and OPEX reduction, easy management and operation, speedy innovation deployment without interfering in-service networks, and efficient resource utilisation.

IV. CONCLUSIONS AND OVERVIEW

In the planned 5G ESSENCE approach, the Small Cell concept has been further evolved as not only to offer multi-operator radio access, but also, to realize an increase in the capacity and the performance of existing RAN infrastructures, and to “spread” the range of the delivered services, while simultaneously maintaining its agility. To attain these ambitious aims, the 5G ESSENCE approach leverages the paradigms of RAN scheduling and furthermore provides an enhanced, edge-based, virtualised execution environment attached to the small cell, taking advantage and reinforcing the concepts of MEC and network slicing. Based upon the innovative framework of the previous 5G-PPP (phase 1) SESAME project, we identify the respective challenges and we propose a more enhanced architectural framework so that to fulfil the new challenges, with the aim of satisfying real life demonstrations in the fields of multimedia/entertainment, mission critical communications at emergency events, and in-flight connectivity and entertainment. We focus upon the essential components of the new architecture and identify perspectives for growth and development.

ACKNOWLEDGMENT

The paper has been based on the context of the 5G-PPP phase 2 “5G ESSENCE” (“*Embedded Network Services for 5G Experiences*”) Project (GA No.761592), funded by the European Commission.

REFERENCES

- [1] European Parliament Think Tank, “5G network technology: Putting Europe at the leading edge”, 2016 (January).

- [2] European Commission and 5G-PPP, "5G Vision: The 5G-PPP Infrastructure Private Public Partnership: The Next Generation of Communication Network and Services", 2015.
- [3] T.S. Rappaport, S. Run, R. Mayzus, H. Zhao, Y. Azar, K. Wang, G.N. Wong, et al., "Millimeter wave mobile communications for 5G cellular: It will work!", IEEE Access, vol.1, pp.335-349, 2013.
- [4] Ericsson, "White Paper on 5G Radio Access", Uen 284 23-3204 Rev C, 2016 (April).
- [5] W. Bock, P. Soos, M. Wilms, and M. Mohan, "Five Priorities for Achieving Europe's Digital Single Market". The Boston Consulting Group Inc., 2015.
- [6] SESAME H2020 5G-PPP Project (Grant Agreement No.671596). <http://www.sesame-h2020-5g-ppp.eu/Home.aspx>.
- [7] European Telecommunications Standards Institute (ETSI), "Mobile-Edge Computing Introductory Technical White Paper", 2014.
- [8] European Telecommunications Standards Institute (ETSI), "Network Functions Virtualisation - Introductory White Paper," 2012.
- [9] SESAME 5G-PPP Project (GA No.671596), Deliverable 2.3 ("Specification of the CESC Components – First Iteration").
- [10] SESAME 5G-PPP Project (GA No.671596), Deliverable 2.4 ("Specification of the Infrastructure Virtualisation, Orchestration and Management").
- [11] SESAME 5G-PPP Project (GA No.671596), Deliverable 4.1 ("Light DC Architecture Design").
- [12] A. Maeder, M. Lalam, et al., "Towards a flexible functional split for cloud-RAN networks". In Proceedings of EuCNC-2014, Bologna, Italy, June 26-29, 2014. IEEE, pp.1-5, 2014.
- [13] P. Rost, C.J. Bernardos, A. De Domenico, et al., "Cloud Technologies for Flexible 5G Radio Access Networks", IEEE Communications Magazine, vol.52(5), pp.68-76, 2014.
- [14] A. Checko, H.L. Christiansen, Y. Yan, L. Scolari, G. Kardaras, M.S. Berger, and L. Dittmann, "Cloud RAN for Mobile Networks - A Technology Overview", IEEE Communications Surveys & Tutorials, vol.17(1), pp.405-426, 2015.
- [15] Fujitsu Network Communications Inc., "The Benefits of Cloud-RAN Architecture in Mobile Network Expansion", 2014. Available at: <http://www.fujitsu.com/downloads/TEL/fnc/whitepapers/CloudRANwp.pdf>
- [16] M.Y. Arslan, K. Sundaresan, and S. Rangarajan, "Software-defined networking in cellular radio access networks: Potential and challenges", IEEE Commun. Mag., vol. 53(1), pp.150-156, 2015.
- [17] B.N. Astuto, M. Mendon, et al., "A Survey of Software-Defined Networking: Past, Present, and Future of Programmable Networks", IEEE Communications Surveys and Tutorials, vol.16(3), pp.1617-1634, 2014.
- [18] S. Chia, M. Gasparoni, and P. Brick, "The next challenge for cellular networks: Backhaul", IEEE Microwave Magazine, vol.10(5), pp.54-66, 2009.
- [19] Huawei Technologies Co. Ltd. "Centralized Operations: Strategies for Today and Tomorrow" (Managed Services White Paper), 2014.
- [20] R. Wang, H. Hu, and X. Yang, "Potentials and Challenges of C-RAN Supporting Multi-RATs Toward 5G Mobile Networks", IEEE Access, vol.2, pp.1187-1195, 2015.
- [21] H. Yan, "A Practical System for Centralized Network Control", CMU-CS-10-149, Thesis. Carnegie Mellon University, Pittsburgh, PA, 2010 (November).
- [22] White Papers from the 5G Infrastructure Association. Available at: <https://5g-ppp.eu/white-papers>
- [23] Small Cell Forum (SFC), "Small cells – what's the big idea?" (White Paper). SFC, 2012 (February).
- [24] I.P. Chochliouros, I. Giannoulakis, et al., "A Model for an Innovative 5G-Oriented Architecture, based on Small Cells Coordination for Multi-tenancy and Edge Services". In Proceedings of AIAI-2016 Int. Conf., IFIP AICT vol.475, L. Iliadis and I. Maglogiannis, Eds. Springer International Publishing Switzerland, 2016, pp. 666-675.
- [25] L. Goratti, et al. (2016): "Network Architecture and Essential Features for 5G: The SESAME Project Approach". In Proceedings of AIAI-2016 Int. Conf., IFIP AICT vol.475, L. Iliadis and I. Maglogiannis, Eds. Springer International Publishing Switzerland, 2016, pp.676-685.
- [26] SESAME 5G-PPP Project (GA No.671596), Deliverable 2.2 ("Overall System and Architecture"). Available at: <http://www.sesame-h2020-5g-ppp.eu/Deliverables.aspx>
- [27] SESAME 5G-PPP Project (GA No.671596), Deliverable 2.3 ("Specification of the CESC Components – First Iteration").
- [28] SESAME 5G-PPP Project (GA No.671596), Deliverable 3.1 ("CESC Prototype design specifications and initial studies on Self-X and virtualization aspects"). Available at: <http://www.sesame-h2020-5g-ppp.eu/Deliverables.aspx>
- [29] SESAME 5G-PPP Project (GA No.671596), Deliverable 2.4 ("Specification of the Infrastructure Virtualisation, Orchestration and Management").
- [30] I.Giannoulakis, et al., "Enabling Technologies and Benefits of Multi-Tenant Multi-Service 5G Small Cells", In Proceedings of the EuCNC-2016 Conference, Athens, Greece, June 27-30, 2016.
- [31] J. Pettit, J. Gross, et al., "Virtual Switching in an Era of Advanced Edges". In Proceedings of the 23rd International Teletraffic Congress (ITC23) / The 2nd Workshop on Data Centre Converged and Virtual Ethernet Switching (DC-CAVES). San Francisco, September 08, 2011.
- [32] Huawei Technologies Co. Ltd. "White Paper – Huawei Observation to NFV", 2014.
- [33] M. Mohri, A. Rostamizadeh, and A. Talwakar, Foundations of Machine Learning. The MIT Press 2011.
- [34] S. Redana, A. Kaloxylou et al., "Views on 5G Architecture", White paper of the 5G-PPP architecture WG, July, 2016.
- [35] F.Z. Yousaf, and T. Taleb, "Fine-grained Resource-aware Virtual Network Function Management for 5G Carrier Cloud", IEEE Network, vol.30(2), pp.110-115, 2016.
- [36] P. Rost, A. Banchs, I. Berberana, M. Doll, et al., "Mobile Network Architecture Evolution Toward 5G", IEEE Communications Magazine, vol.54(5), pp.84-91, 2016.
- [37] M. Richart, J. Balosian, J. Serrat, and J.-L.Gorricho, "Resource Slicing in Virtual Wireless Networks: A Survey", IEEE Trans. on Network and Service Management, vol.13(3), pp. 462-476, Sept. 2016
- [38] C.-L. I, J. Huang, R. Duan, C. Cui, J.(X.) Jiang, and L. Li, "Recent Progress on C-RAN Centralization and Cloudification", IEEE Access, vol.2, pp.1030-1039, 2014
- [39] P. Hedman, Description of Network Slicing Concept (NGMN 5G P1). NGMN (Next Generation Mobile Networks) Alliance 2016.
- [40] X. Costa-Perez, J. Swetina, T. Guo, R. Mahindra, and S. Rangarajan, "Radio Access Network Virtualization for Future Mobile Carrier Networks", IEEE Communications Magazine, vol.51(7), pp.27-35, 2013.
- [41] I.P. Chochliouros, et al., "Challenges for Defining Opportunities for Growth in the 5G Era: The SESAME Conceptual Model", In Proceedings of the EuCNC-2016, Athens, Greece, June 27-30, 2016.
- [42] G.A. Khan, et al., "Network sharing in the next mobile network: TCO reduction, management flexibility, and operational independence", IEEE Communications Magazine, vol.49(10), pp.134-142, 2011.
- [43] K. Samdanis, X. Costa-Perez, and V. Sciancalepore, "From Network Sharing to Multi-Tenancy: The 5G Network Slice Broker", IEEE Communications Magazine, vol.54(7), pp.32-39, 2016.
- A. Khan, W. Kellerer, K. Kozu, and M. Yabusaki, "Network sharing in the next mobile network: TCO reduction, management flexibility, and operational independence", IEEE Communications Magazine, vol.49(10), pp.134-142, 2011.